

BILLARDS
Chevillotte
— Depuis 1860 —





Histoire du billard

Billiard history

La première table de billard fut construite en 1469 pour Louis XI. En France, le succès est immédiat ; en 1630 on peut compter 150 tables à Paris dans les premières académies. Louis XVI jouait au billard dès son plus jeune âge et jusqu'au XVIIIème siècle, les femmes jouaient autant au billard que les hommes. Sous l'empire, Napoléon se révélait être un fervent adepte de cette discipline.

C'est vers 1850 qu'apparaît l'actuel billard français à 3 billes et c'est en 1873 qu'a lieu le premier championnat du monde professionnel.

En bois de chêne jusqu'à la première moitié du XIX^{ème} siècle, la table de jeu est remplacée par de la pierre ou du marbre (jusqu'en 1900 environ) pour faire place aujourd'hui à l'ardoise, matériau irremplaçable encore jamais égalé. Actuellement, le billard continue à connaître un essor particulier et se pratique dans le monde entier.

Dès 1860, Eugène Chevillotte s'intéressera et contribuera au développement du billard en France, jusqu'à faire du nom Chevillotte le synonyme de billard de qualité.

The billiard game was born in France, where the first billiard table was built for King Louis XI in 1429. Popularity of the game increased rapidly and between 1550 and 1630 the first Billiard leagues were created.

Kings and the great Royal ladies played the game with passion (in the 18th century women used to play billiard as much as men).

French Billiard or Carom, played with 3 balls appeared in 1850. Numerous competitions were organized and in 1873 the first championship was held.

Until the first half of 19 century, the game area of the table was made of oak, wood was then replaced by stone or marble until 1900. Since then, slate has been the preferred material, and no other superior replacement material has yet been found.

Today billiards game continues to expand and is played all over the world in many game modes.

In 1860, Eugene Chevillotte focused on pool table market with the consequence of making his family name a famous brand of billiard with a strong reputation of excellence.



Depuis 1860, Chevillotte incarne dans le monde l'exigence et la perfection dans la fabrication de tables de billards. Depuis 5 générations, la Maison met tout en œuvre pour satisfaire les amateurs d'esthétique et de performance.

Son savoir-faire unique s'illustre à la fois dans la restauration de billards anciens, dans la réalisation de projets sur-mesure et dans la conception de tables de billard innovantes et évolutives.

Chevillotte propose également une gamme complète d'accessoires et de jeux et un service de conception et d'aménagement d'espaces de détente (concept Entertainment Room).

Since 1860, Chevillotte embodies all over the world the requirement and perfection in the manufacture of billiard tables. The manufacture makes every effort to meet the demands of performance and aesthetic.

Over the years, Chevillotte has created a real distinctive know-how in the complete restoration of antique pool tables, in the manufacture of modern scalable pool tables and in the conception of tailor-made products.

Chevillotte also offers a large range of accessories, games tables and games (backgammon, poker kits, kits casino, football, multi-game tables, poker tables...) to create a festive and friendly atmosphere around the pool. Chevillotte Entertainment Room is a service providing the creation of made to measure entertainment areas.

Histoire de la société

Company history



Napoléon III,
Ecole Boule, 17^{ème} siècle



Charles X,
Pied olive / Olive feet

Billards anciens *Antique billiards*

Passée spécialiste de la restauration et de la reproduction de billards anciens, Chevillotte s'attache à donner aux pièces anciennes les qualités de jeu de billards modernes. Ainsi, un billard restauré par Chevillotte apporte la double satisfaction de jouer sur une surface techniquement parfaite et celle de posséder un meuble d'exception de grande valeur.

Since 1860, we are passionate about billiards. It becomes a natural evolution to restore old billiards. As jewels of art and unique pieces of cabinetry, they are the testimony of a time period and the evidences of the values of our heritage. Here are the main phases involved with a typical restoration...



Louis XVI



Napoléon III
Marqueterie / Marquetry



Art Déco

Restauration *Restoration*



Billard Ancien 19^{ème} siècle avec son parquet d'origine en bois, et son tour de bande endommagé. Les dommages à réparer sont considérables : patience et colle à l'ancienne... Un plateau d'ardoise remplace le parquet de bois. *For a 19th century billiards table with original wood tray, old bouncing strips in fabric. Major damages to repair: patience and old-fashioned glue. A slate tray replaces the wood tray.*



Mise en place des bandes caoutchouc. Découpe et rabotage des bandes. Traçage de la marqueterie. Découpe des composants de la nouvelle marqueterie. Mise en place de la marqueterie. *Setting up the new rubber strips. Trimming of the wood brackets. Tracing the old inlay. Cutting the components for the new inlay. Setting up the inlay.*



Vernissage au tampon. Restauration et patine des bronzes. Les bandes caoutchouc sont recouvertes du drap (garnissage). Assemblage de tous les éléments... Application des bronzes et dorures sur le meuble. *French varnishing of the cabinetry. Bronzes are sanded and given a patina. The rubber strips are covered with a cloth (filling). Re-assembly of the components. And gold imitations are applied on the furniture.*

Le Billard du Roi

The King's Billiard

Passionné de billard, le Roi Louis XVI s'offrit en 1776 un billard exceptionnel, livré par Masson « Paumier de sa Majesté », en beau bois de chêne de 3,90 m de long sur 1,90 m de large et garni d'un fin drap de laine d'Espagne. C'est tout naturellement à la Maison Chevillotte, référence en matière de restauration de billard ancien, que le Château de Versailles a fait appel en 2006 afin de restituer ce billard dans le cadre d'un mécénat de compétence.

Chevillotte name has always been nobly associated with the manufacture of fine billiard tables. This was reflected in the choice of Chevillotte for the restoration of King Louis XVI's billiard table in the Versailles Castle.

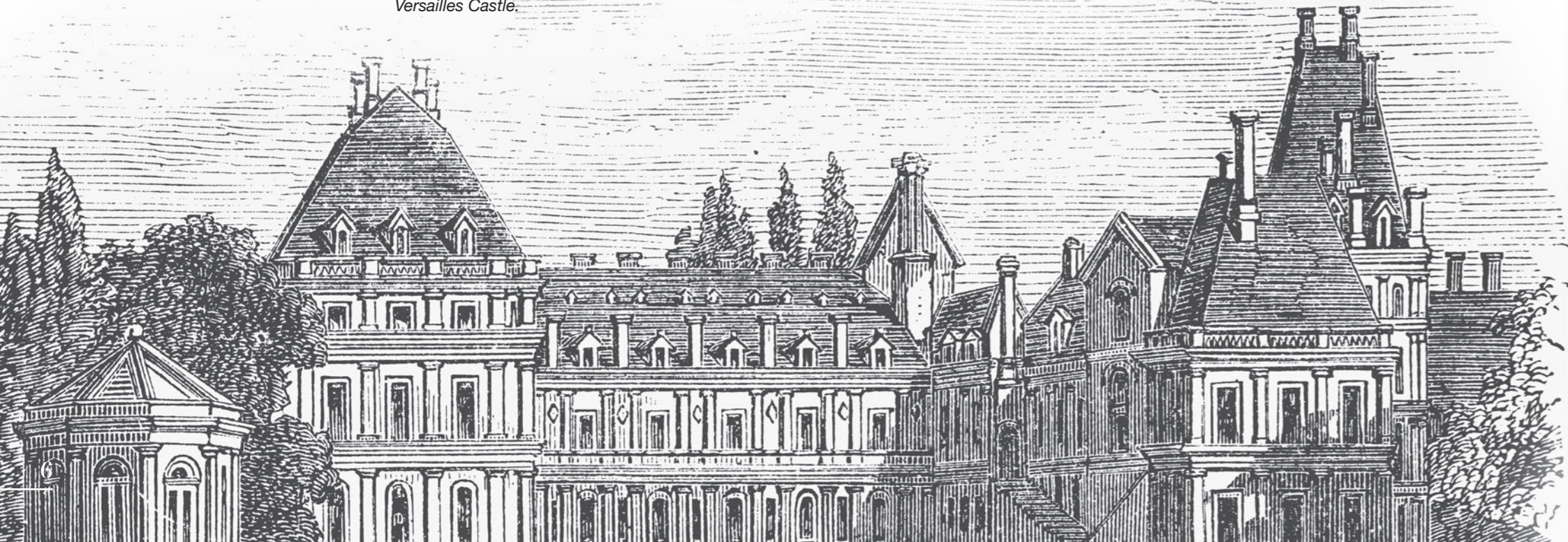

Caractéristiques techniques

Specifications

- Chêne massif de France sélectionné et séché par nos soins. *Specially selected solid French dried oak*
- Galons de fils d'or. *Gold laced thread*
- Clous et visseries dorés à l'or fin. *Finely gold gilded nails and screws.*
- Drap 100% pure laine vierge. *100 % pure virgin wool cloth, a selection of some of the finest combed wool providing a perfectly flat and precise playing surface.*
- Disponible en mode de jeu Français ou Américain. *Available in one size in Carom and American Pool.*

Dimensions / Overall dimensions (cm)

| Tour de bande Cushion Frame | Surface de jeu Playing surface | Hauteur Height |
|--------------------------------|-----------------------------------|-------------------|
| 286 x 150 | 254 x 127 | 85 |

JEU / GAME



Plus de détails / More details p43

FINITION / FINISH



Excellence

Dans le clair-obscur de nos ateliers, meubles d'époque et copie d'anciens se content leur histoire. Ils partagent les mêmes matières au-delà du temporel. Le modèle Excellence autorise toutes les audaces : bois précieux, blasons personnalisés, mélanges des matières...

La marqueterie nuancée s'adapte subtilement sur les formes ancestrales de ce modèle qui offre une technicité de jeu contemporaine de qualité inégalable.

In the soft light of our workshop, original furniture and reproduction pieces tell their story to each other. Regardless of time periods, they share the same raw materials. Ancestral shapes are subtly drawn in a delicate inlay pattern that fits very well with the contemporary techniques offering an unmatched quality of game.

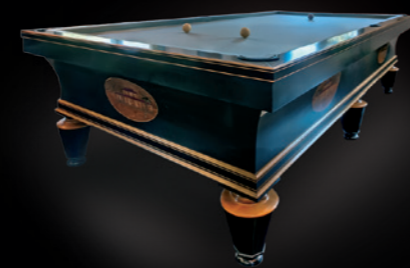

Type 310 • Snooker • Kotibé massif & citronnier • Teinte ébène • Marqueterie
10 ft • Snooker • Solid African mahogany & lemon tree • Ebony tint • Fine marquetry



Type 310 • Snooker • Kotibé massif & citronnier • Palissandre • Pieds sculptés et dorés • Marqueterie
10 ft • Snooker • Solid African mahogany & lime • Palissandre veneered • Gilded carved legs • Fine marquetry



Type 260 • Carombole • Noyer massif • Plaquage loupe d'érable • Marqueterie
8 ft • Carom • Solid French walnut • Burr walnut veneered • Fine marquetry



Type 385 • Pyramide Russe • Kotibé massif • Plaquage merisier • Pieds en bronze • Marqueterie
12 ft • Pyramid • Solid African mahogany • Wild cherry tree veneered • Bronze legs • Fine marquetry



Type 240 • Pool • Kotibé massif • Palissandre • Marqueterie
7 ft • US pool • Solid African mahogany • Palissandre veneered • Fine marquetry



Type 385 • Pyramide Russe • Descente intérieure • Kotibé massif • Teinte merisier • Marqueterie sur mesure
12 ft • Pyramid • Ball return system • Solid African mahogany • Cherry tree veneered • Fine marquetry

| Type | Dimensions (cm) | | | | Poids / Weight (Kg / Lb) | |
|-----------|-------------------|-----------|---------------|------------|--------------------------|---------------------------|
| | Hors tout Overall | Jeu Game | Pièce* Space* | Pieds Legs | FR Carom | US / GB / RU Pocket Games |
| 240 / 7' | 242 x 137 | 210 x 105 | 500 x 395 | 4 | 500 / 1102 | 400 / 881 |
| 260 / 8' | 262 x 147 | 230 x 115 | 520 x 405 | 4 | 550 / 1212 | 480 / 1058 |
| 280 / 9' | 286 x 159 | 254 x 127 | 544 x 417 | 6 | 750 / 1653 | 595 / 1311 |
| 310 / 10' | 316 x 174 | 284 x 142 | 574 x 432 | 6 | 1000 / 2204 | 850 / 1874 |
| 385 / 12' | 388 x 209 | 356 x 177 | 660 x 485 | 8 | - / - | 1250 / 2755 |

* Dimensions minimales de la pièce en utilisant une queue de 140 / Minimum space required to play with 4,5' cue

JEU / GAME

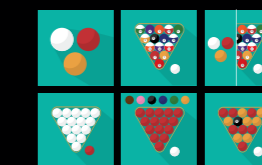

FINITIONS / FINISH



OPTION

Blason, filets de bois de citronnier, et marqueterie.

Coat of arm, Lemon Tree inlays and marquetry upon sample

Plus de détails / More details p43

Guyenne



La noblesse du Noyer de France massif trouve sa plus haute expression dans le dessin parfait des moulures et des galbes ainsi que dans l'harmonie des formes de ce modèle.

Inspiré du style Louis Philippe, le Guyenne conjugue avec talent les qualités d'une grande table de jeu et la valeur sûre d'un meuble d'exception conçu dans le respect des règles immuables de la haute ébénisterie.

It rules over all it surveys. The character and elegance of its curves make the Guyenne an uncompromising favorite in terms of looks and playing quality.

Inspired from the Louis Philippe Style, Guyenne offers the performances of a great pool table and the guaranty of a great piece of cabinetry due to the warmth and the nobility of the old solid French walnut.

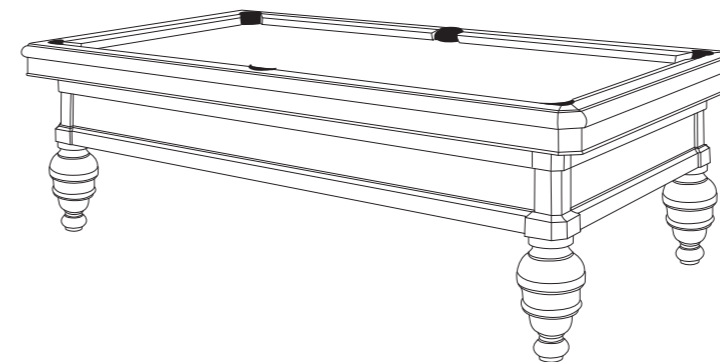

| Type | Dimensions (cm) | | | | Poids / Weight (Kg / Lb) | |
|-----------|-------------------|-----------|---------------|------------|--------------------------|---------------------------|
| | Hors tout Overall | Jeu Game | Pièce* Space* | Pieds Legs | FR Carom | US / GB / RU Pocket Games |
| 240 / 7' | 244 x 139 | 210 x 105 | 500 x 395 | 4 | 500 / 1102 | 400 / 881 |
| 260 / 8' | 264 x 148 | 230 x 115 | 520 x 405 | 4 | 550 / 1212 | 480 / 1058 |
| 280 / 9' | 288 x 161 | 254 x 127 | 544 x 417 | 6 | 750 / 1653 | 595 / 1311 |
| 310 / 10' | 318 x 176 | 284 x 142 | 574 x 432 | 6 | 1000 / 2204 | 850 / 1874 |
| 385 / 12' | 390 x 211 | 356 x 177 | 660 x 485 | 8 | - / - | 1250 / 2755 |

* Dimensions minimales de la pièce en utilisant une queue de 140 / Minimum space required to play with 4,5' cue

JEU / GAME

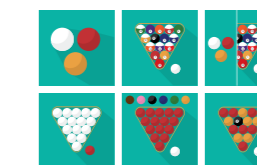

FINITIONS / FINISH



OPTION

Plus de détails / More details p43

Périgord



Inspiré d'une table de jeu du XIX^e siècle, le Périgord fait revivre l'esprit et la poésie de nos styles régionaux les plus représentatifs et les plus prestigieux. Volumes et robe dorée font de ce modèle en Noyer de France massif une pièce de collection digne de satisfaire les amateurs les plus exigeants.

Made entirely of solid Périgord walnut, it stands prominently in the image of the species itself. Its simple lines combine opulence, balance and smoothness: a fine example of restrained sophistication. Its presence will fill your home with a rich regional scent, while the waxed patina adds a warm sensuality and sense of peace.

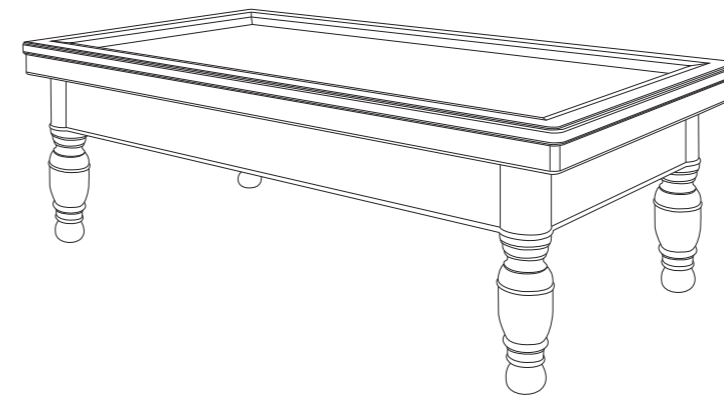

| Type | Dimensions (cm) | | | | Poids / Weight (Kg / Lb) | |
|-----------|-------------------|-----------|---------------|------------|--------------------------|---------------------------|
| | Hors tout Overall | Jeu Game | Pièce* Space* | Pieds Legs | FR Carom | US / GB / RU Pocket Games |
| 240 / 7' | 244 x 139 | 210 x 105 | 500 x 395 | 4 | 455 / 1003 | 380 / 837 |
| 260 / 8' | 264 x 148 | 230 x 115 | 520 x 405 | 4 | 525 / 1157 | 430 / 947 |
| 280 / 9' | 288 x 161 | 254 x 127 | 544 x 417 | 6 | 780 / 1719 | 560 / 1234 |
| 310 / 10' | 318 x 176 | 284 x 142 | 574 x 432 | 6 | 1050 / 2315 | 850 / 1874 |
| 385 / 12' | 390 x 211 | 356 x 177 | 660 x 485 | 8 | 1260 / 2778 | - / - |

* Dimensions minimales de la pièce en utilisant une queue de 140 / Minimum space required to play with 4,5' cue

JEU / GAME

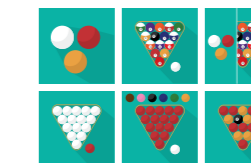

FINITIONS / FINISH



OPTION

Plus de détails / More details p43

Louis XVI

Prestige



Son harmonie est une invitation aux moments privilégiés. Destiné à vieillir à vos côtés, il restera fidèle à ses promesses et longtemps il provoquera émotion et admiration. Véritable pièce d'ébénisterie, il conjugue élégance, style et raffinement.

Conçu selon les normes les plus rigoureuses à partir de matériaux nobles, il restitue les qualités et les réactions des billards réservés aux compétitions internationales.

Its harmony is an invitation to special moments. Louis XVI Prestige is primarily an investment. Designed to grow old with you as a true piece of cabinet, it combines elegance, style and refinement.

Manufactured in the state of art from high quality materials, Louis XVI offers the game performances of pool tables reserved for international competitions.

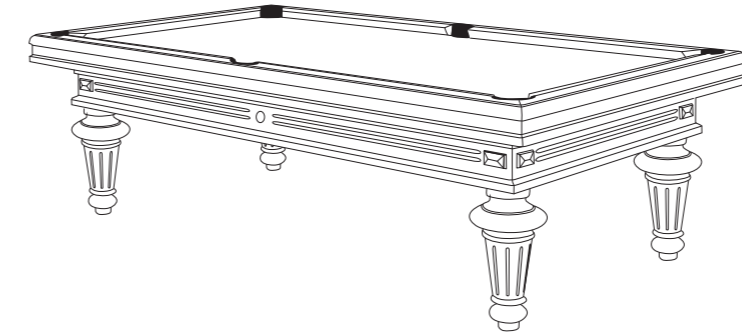

| Type | Dimensions (cm) | | | | Poids / Weight (Kg / Lb) | |
|-----------|-------------------|-----------|---------------|------------|--------------------------|---------------------------|
| | Hors tout Overall | Jeu Game | Pièce* Space* | Pieds Legs | FR Carom | US / GB / RU Pocket Games |
| 240 / 7' | 242 x 137 | 210 x 105 | 500 x 395 | 4 | 455 / 1003 | 380 / 837 |
| 260 / 8' | 262 x 147 | 230 x 115 | 520 x 405 | 4 | 525 / 1157 | 430 / 947 |
| 280 / 9' | 286 x 159 | 254 x 127 | 544 x 417 | 6 | 780 / 1719 | 560 / 1234 |
| 310 / 10' | 316 x 174 | 284 x 142 | 574 x 432 | 6 | 1050 / 2315 | 850 / 1874 |
| 385 / 12' | 388 x 209 | 356 x 177 | 660 x 485 | 8 | - / - | 1260 / 2778 |

* Dimensions minimales de la pièce en utilisant une queue de 140 / Minimum space required to play with 4,5' cue

JEU / GAME

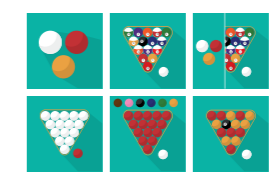

FINITIONS / FINISH



OPTION

Plus de détails / More details p43

Louis XVI Tradition



Modèle Louis XVI Tradition, un signe intérieur et extérieur de savoir-vivre ! Plaisir des yeux, plaisir du jeu, sa sobriété a le pouvoir de valoriser ce qui l'accompagne, l'élégance subtile de sa ligne, le raffinement de ses finitions représentent un gage de séduction permanent pour le confort de votre intérieur.

Louis XVI Tradition is a safe bet: you will never get disappointed as its style is henceforth classic and timeless. The perfect balance of its lines and the many versions of the Tradition model are probably responsible for the old adage that a billiard table is a man's best friend.

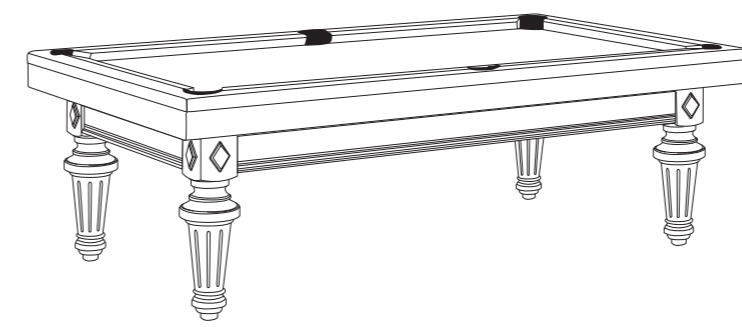

| Type | Dimensions (cm) | | | | Poids / Weight (Kg / Lb) | |
|----------|-------------------|-----------|---------------|------------|--------------------------|---------------------------|
| | Hors tout Overall | Jeu Game | Pièce* Space* | Pieds Legs | FR Carom | US / GB / RU Pocket Games |
| 240 / 7' | 242 x 137 | 210 x 105 | 500 x 395 | 4 | 455 / 1003 | 380 / 837 |
| 260 / 8' | 262 x 147 | 230 x 115 | 520 x 405 | 4 | 525 / 1157 | 430 / 947 |
| 280 / 9' | 286 x 159 | 254 x 127 | 544 x 417 | 6 | 780 / 1719 | 560 / 1234 |

* Dimensions minimales de la pièce en utilisant une queue de 140 / Minimum space required to play with 4,5' cue

JEU / GAME

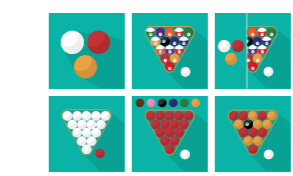

FINITIONS / FINISH

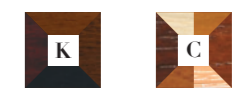

OPTION

Plus de détails / More details p43

Gasconne



Fleuron de notre tradition gastronomique, la Gasconne insuffle à ce billard sa culture du savoir-vivre et en fait une invitation aux arts de la table. Transformé en table d'hôtes avec son plateau et son banc, Gasconne réunit 8 à 12 convives.

Gasconne is famous for its French cuisine and hospitality. This model is faithful to the Gascon tradition: it can be transformed into a beautiful and welcoming host table (8 to 10 guests). Its classical design will blend seamlessly with your interior and bring it all the splendor of antique furniture.

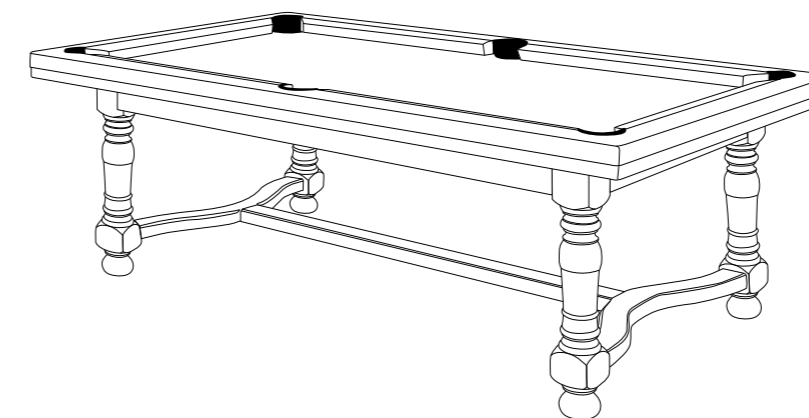

| Type | Dimensions (cm) | | | | Poids / Weight (Kg / Lb) | |
|----------|-------------------|-----------|---------------|------------|--------------------------|---------------------------|
| | Hors tout Overall | Jeu Game | Pièce* Space* | Pieds Legs | FR Carom | US / GB / RU Pocket Games |
| 220 / 6' | 222 x 127 | 190 x 95 | 480 x 385 | 4 | 350 | 280 |
| 240 / 7' | 242 x 137 | 210 x 105 | 500 x 395 | 4 | 450 | 370 |
| 260 / 8' | 262 x 147 | 230 x 115 | 520 x 405 | 4 | 520 | 430 |

* Dimensions minimales de la pièce en utilisant une queue de 140 / Minimum space required to play with 4,5' cue

JEU / GAME

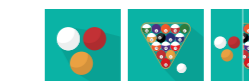

Plus de détails / More details p43

FINITIONS / FINISH



OPTION



Europa Master

La référence Mondiale en compétition. Depuis plus d'un siècle, les Billards Chevillotte contribuent à écrire l'histoire sportive du billard. L'Europa Master est la référence mondiale en compétition. Son design allie performance de jeu et esthétique et se décline en version Carom, Pool, Snooker et Pyramide Russe.

In the world of championships, the Europa Master has always been the reference and is regularly selected for the major competitions. The most demanding players enjoy its precision and design. Its black laminated and lacquers finishes allow this model to be integrate at home. Europa Master is the top of the line for billiard rooms.

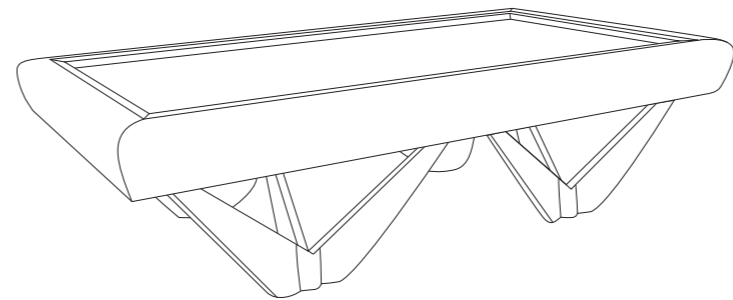

| Type | Style | Dimensions (cm) | | | Pieds Legs | Poids / Weight |
|-----------|--------------------|----------------------|-------------|------------------|---------------|----------------|
| | | Hors tout Overall | Jeu Game | Pièce* Space* | | (Kg / Lb) |
| 280 / 9' | Carom | 280 x 153 | 254 x 127 | 544 x 417 | 4 | 900 / 1980 |
| 280 / 9' | Pool | 280 x 153 | 254 x 127 | 544 x 417 | 4 | 600 / 1320 |
| 310 / 10' | Carom | 310 x 168 | 284 x 142 | 574 x 432 | 4 | 1205 / 2660 |
| | Snooker | | | | | |
| 385 / 12' | Russian Pyramid | 383 x 204 | 356 x 177 | 660 x 485 | 4 | 1380 / 3040 |

* Dimensions minimales de la pièce en utilisant une queue de 140 / Minimum space required to play with 4,5' cue

JEU / GAME

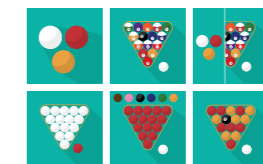

FINITIONS / FINISH



OPTION

Plus de détails / More details p43

Keomaster



Le KEOMASTER a été pensé pour les clubs de billard haut de gamme. Ses lignes sobres, l'équilibre des masses combinées à la présence chaleureuse du bois plongent les joueurs dans une ambiance luxueuse et zen à la fois.

The KEOMASTER was designed for high-end billiard clubs. Its sober lines, the balance of the masses combined with the warm presence of solid premium wood plunge players into a luxurious and zen atmosphere at the same time.

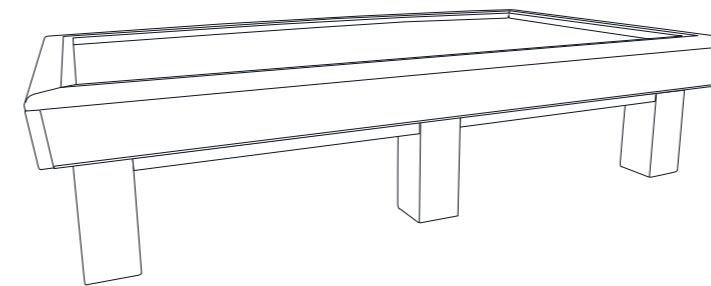
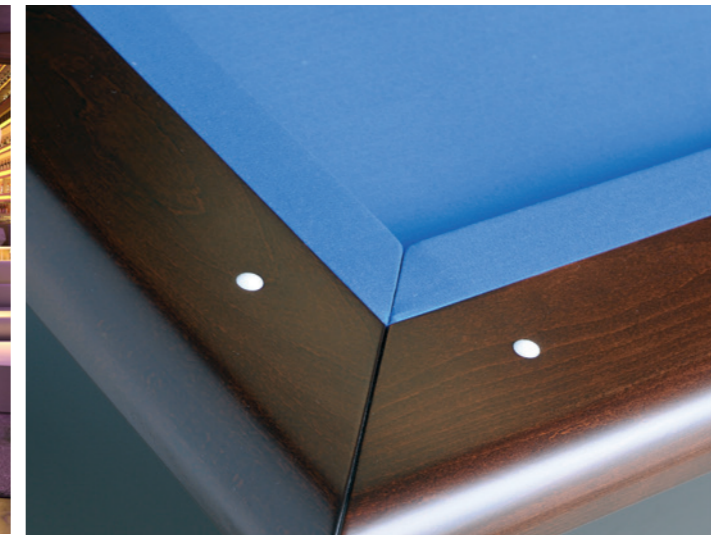

| Type | Style | Dimensions (cm) | | | Pieds Legs | Poids / Weight |
|-----------|-------|----------------------|-------------|------------------|---------------|----------------|
| | | Hors tout Overall | Jeu Game | Pièce* Space* | | (Kg / Lb) |
| 310 / 10' | Carom | 316 x 174 | 284 x 142 | 574 x 432 | 6 | 1100 / 2425 |

* Dimensions minimales de la pièce en utilisant une queue de 140 / Minimum space required to play with 4,5' cue

JEU / GAME



FINITIONS / FINISH



Plus de détails / More details p43

Antares



La sobriété et la superposition architecturée des lignes apportent au modèle Antarès un équilibre parfait qui se décline dans une palette infinie de possibilités (laques, finitions satinées, plaquage bois exotique, garnissage cuir...) pour une intégration parfaite dans tous types d'intérieur.

Its perfect balance relies upon layering of architectural lines. The unconventional angles and the shape of its legs give an impression of strength and serenity. The large number of possibilities for its customization allows the expression of your creativity: lacquers, exotic wood veneered, leather, wood finish, solid wood...there is no limit to your imagination.

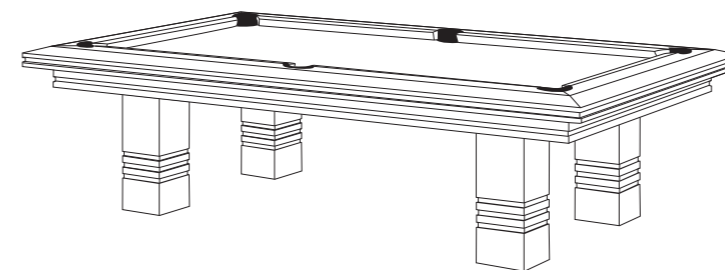

| Type | Dimensions (cm) | | | | Poids / Weight (Kg / Lb) | |
|-----------|-------------------|-----------|--------------|------------|--------------------------|---------------------------|
| | Hors tout Overall | Jeu Game | Pièce Space* | Pieds Legs | FR Carom | US / GB / RU Pocket Games |
| 240 / 7' | 257 x 152 | 210 x 105 | 500 x 395 | 4 | 540 / 1190 | 460 / 1014 |
| 260 / 8' | 277 x 162 | 230 x 115 | 520 x 405 | 4 | 610 / 1344 | 520 / 1146 |
| 280 / 9' | 301 x 174 | 254 x 127 | 544 x 417 | 6 | 940 / 2073 | 730 / 1609 |
| 310 / 10' | 331 x 189 | 284 x 142 | 574 x 432 | 6 | 1270 / 2800 | 1070 / 2359 |
| 385 / 12' | 403 x 225 | 356 x 177 | 660 x 485 | 8 | - / - | 1450 / 3196 |

* Dimensions minimales de la pièce en utilisant une queue de 140 / Minimum space required to play with 4,5' cue

JEU / GAME

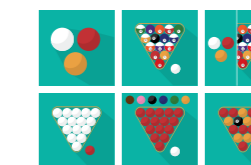

FINITIONS / FINISH



MDF/HDF OPTION

Plus de détails / More details p43

Concorde



Equilibre parfait des droites et des courbes, le modèle Concorde conjugue brillamment efficacité et esthétique contemporaine. Une palette de laques créatives avec 150 coloris aux choix autorise toutes les audaces.

The Concorde design offers a perfect harmony between straight lines and curves. Its slate successfully combines rational features and full scale aesthetic.

A creative palette of lacquers with 150 colors choices allows all boldness and customizations for perfect integration into any kind of interior.

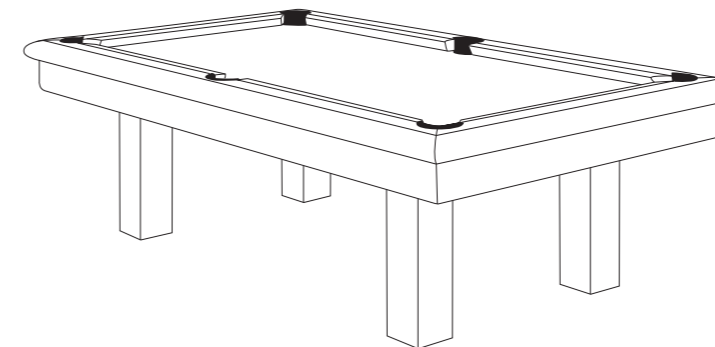
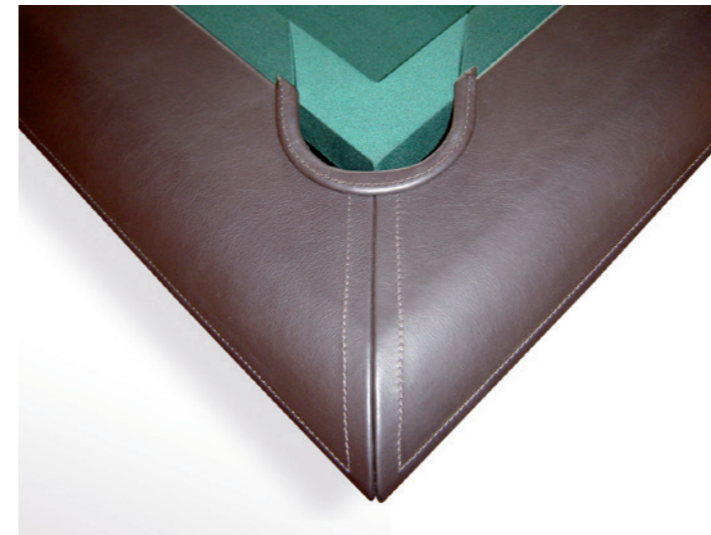

| Type | Dimensions (cm) | | | | Poids / Weight (Kg / Lb) | |
|-----------|-------------------|-----------|----------------------|------------|--------------------------|---------------------------|
| | Hors tout Overall | Jeu Game | Pièce* Pièce* Space* | Pieds Legs | FR Carom | US / GB / RU Pocket Games |
| 240 / 7' | 246 x 141 | 210 x 105 | 500 x 395 | 4 | 500 / 1102 | 415 / 1135 |
| 260 / 8' | 266 x 151 | 230 x 115 | 520 x 405 | 4 | 575 / 1135 | 485 / 1069 |
| 280 / 9' | 290 x 163 | 254 x 127 | 544 x 417 | 6 | 870 / 1018 | 660 / 1455 |
| 310 / 10' | 320 x 178 | 284 x 142 | 574 x 432 | 6 | 1200 / 2645 | 1000 / 2204 |

* Dimensions minimales de la pièce en utilisant une queue de 140 / Minimum space required to play with 4,5' cue

JEU / GAME

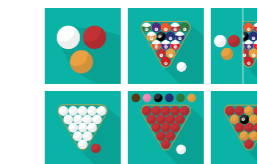

FINITIONS / FINISH



MDF/HDF OPTION

Plus de détails / More details p43

Keops



Une surface de jeu d'une qualité exceptionnelle dans un écran de bois massif, le Kéops de Chevillotte se distingue par son élégance discrète. Ses lignes sobres et fluides, d'une très grande pureté, s'intègrent parfaitement aux décors de tous styles et lui feront passer les années avec une tranquille sérénité. Pièce maîtresse de votre décoration intérieure, il restituera avec panache vos effets et vos trajectoires au cours des parties qui ponctueront vos loisirs.

Naturally timeless, Keops is inspired by cubism and looks quite masculine at the first glance. But, if you observe it with attention, you won't ignore its seductive power due to its sober lines and the warmth of the wood. Very elegant and discreet, Keops will find its place in all interiors setting.

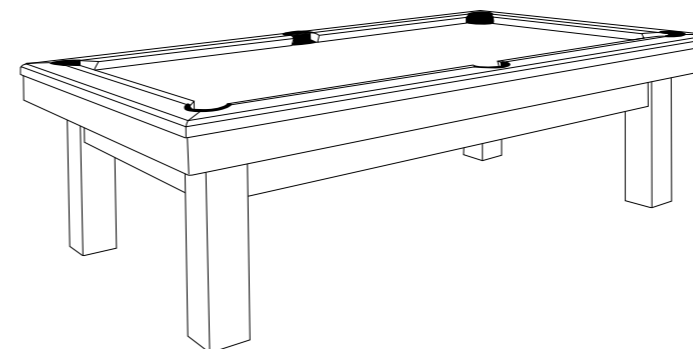

| Type | Dimensions (cm) | | | | Poids / Weight (Kg / Lb) | |
|----------|-------------------|-----------|---------------|------------|--------------------------|---------------------------|
| | Hors tout Overall | Jeu Game | Pièce* Space* | Pieds Legs | FR Carom | US / GB / RU Pocket Games |
| 240 / 7' | 242 x 137 | 210 x 105 | 500 x 395 | 4 | 450 / 992 | 370 / 815 |
| 260 / 8' | 262 x 147 | 230 x 115 | 520 x 405 | 4 | 520 / 1146 | 430 / 947 |
| 280 / 9' | 286 x 159 | 254 x 127 | 544 x 417 | 6 | 740 / 1631 | 520 / 1146 |

* Dimensions minimales de la pièce en utilisant une queue de 140 / Minimum space required to play with 4,5' cue

JEU / GAME

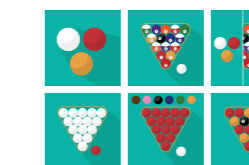

FINITIONS / FINISH



OPTION

Plus de détails / More details p43

Le 150

by 



En 2010 Chevillotte a fêté 150 ans d'histoire et d'un savoir-faire unique au service d'un artisanat de luxe. À cette occasion la Maison s'est associée au designer Eric Raffy pour la création d'un billard à la ligne unique.

In 2010, Chevillotte has celebrated 150 years of a unique know how of excellence and has launched for this special anniversary "Le 150". Chevillotte has collaborated with Eric Raffy for this new pool table. As a result, Le 150 appears like a unique pool table: the thinness of the table and the shift of the legs affirm the character and the originality of this new model available in a large choice of finishes.



*Avec ses pieds miroir, la table semble flotter
A floating table thanks to its mirror finish legs*

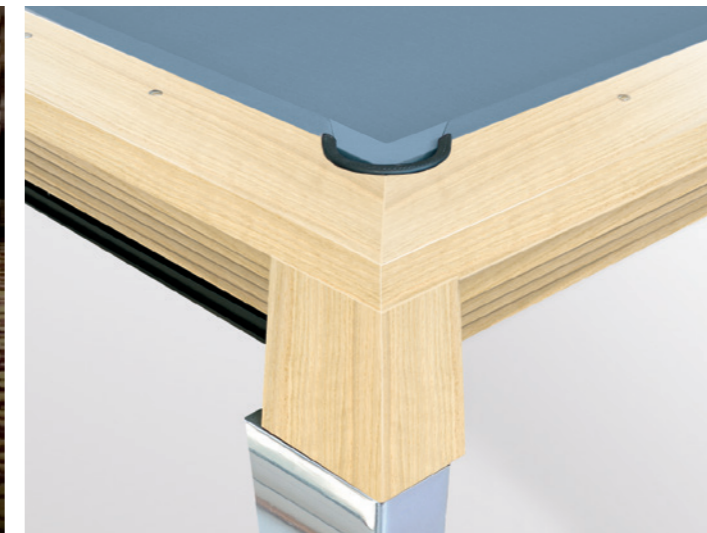

*Le 150 et ses accessoires
150 and accessories*

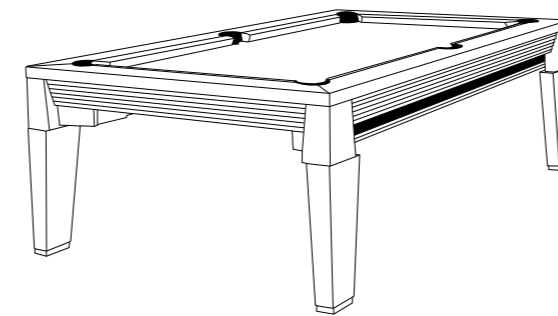

*Pieds bois sur demande
Legs in solid African wood on request*



Design - Raffy Design

Eric Raffy

| Type | Dimensions (cm) | | | | Poids / Weight (Kg / Lb) | |
|------------------|-------------------|-----------|----------------------|------------|--------------------------|---------------------------|
| | Hors tout Overall | Jeu Game | Pièce* Pièce* Space* | Pieds Legs | FR Carom | US / GB / RU Pocket Games |
| 240 / 7' | 250 x 145 | 210 x 105 | 500 x 395 | 4 | 460 / 1014 | 400 / 1102 |
| 260 / 8' | 270 x 155 | 230 x 115 | 520 x 405 | 6 | 580 / 1278 | 520 / 1146 |
| 280 / 9' | 294 x 167 | 254 x 127 | 544 x 417 | 6 | 780 / 1719 | 730 / 1609 |
| 310 / 10' | 324 x 182 | 284 x 142 | 574 x 432 | 8 | 900 / 1984 | |
| 385 / 12' | 396 x 218 | 356 x 177 | 660 x 485 | 8 | 1200 / 2645 | |

** Dimensions minimales de la pièce en utilisant une queue de 140 / Minimum space required to play with 4,5' cue*

JEU / GAME

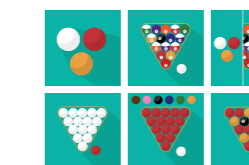

FINITIONS / FINISH



OPTION

Plus de détails / More details p43

(Very)tables®

Design Bernard Moïse

Verytables® est la 1^{ère} table contemporaine (ou bureau) à se transformer en billard grâce à un système exclusif breveté de haute précision. Chevillotte a consacré à Verytables® des matériaux et finitions à la hauteur de son design, pour le plaisir des yeux et du jeu.

For the first time ever, a contemporary dining table or desk can be transformed into a billiard table thanks to a new mechanical and unique system. Initially at the same height as the game surface, the rails are lifted up to create the pool table. The table top is composed of 3 reversible ultra-thin parts which can be put away in a hidden drawer under the table. With this new concept, Chevillotte takes up the challenge of designing, within a standard height dining table or desk, a slate, billiard cushion rails and 16 billiard balls, all in a tabletop of less than 4 inches.



4 in 1

- Table de salle à manger / Dining Table
- Bureau / Desk
- Billard mixte FR/US / American & Carom pool
- Table de poker et de jeux de carte / Poker table

Prix du design par le VIA
VIA Award



Voir vidéo sur / See online video on:
www.chevillotte.com



Table de poker et de jeu
Poker table

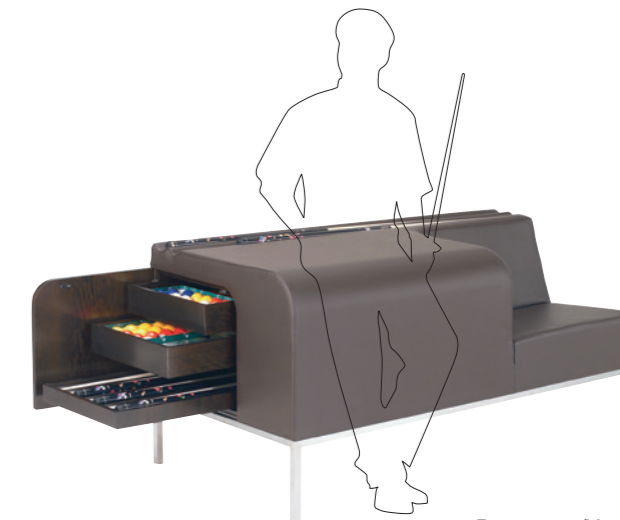
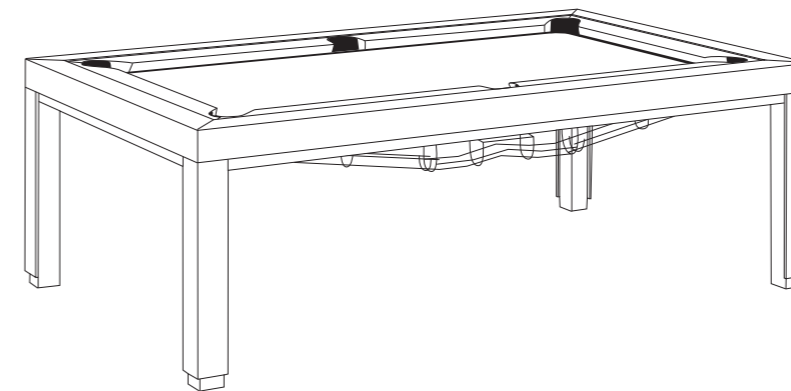

Banquette (Very)tables / (Very)tables Seat
Dimensions (cm) : 170 x 74 x 76



Design - Bernard Moïse Studio

Diplômé de l'Ecole Nationale de Création Industrielle de Paris.
Graduated from the Advanced National School of Design and Industrial Creation, Paris.

| Type | Dimensions (cm) | | | | Hauteur / Height (cm) | | | Poids Weight (Kg / Lb) |
|----------|----------------------|-------------|-----------------|---------------|-----------------------|-------|-----------------------------|---------------------------|
| | Hors tout Overall | Jeu Game | Pièce Space* | Pieds Legs | Pool | Table | Sous table Under table's | |
| 220 / 6' | 233 x 138 | 190 x 95 | 480 x 385 | 4 | 79 | 75 | 59,5 | 300 |

* Dimensions minimales de la pièce en utilisant une queue de 140 / Minimum space required to play with 4,5' cue

FINITIONS / FINISH



JEU / GAME

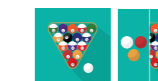

Plus de détails / More details p43

OPTION

Moteur & télécommande
Electrical motor
& remote control

Heimo

La seule vraie table* / The only pool table which is also a real dining table

Avec Heimo, Chevillotte a voulu offrir au plus grand nombre le plaisir de posséder un billard qui allie la performance de jeu aux qualités esthétiques et fonctionnelles d'une très belle table (8 à 10 personnes). Son design épuré d'inspiration Nordique et ses nombreuses teintes sauront s'intégrer harmonieusement dans tous les intérieurs contemporains.

With Heimo, Chevillotte offers the pleasure to play on a real performing pool that combines the aesthetic and functional qualities of a beautiful table with contemporary design. Heimo was designed primarily as a table that can adapt to all circumstances. Equipped with its table top, Heimo will gather your family and friends around a good meal or a game. Its sober and pure design, inspired from Nordic atmosphere, and its light and ebony finishes will integrate easily into any contemporary interior.



Version chêne / Solid oak

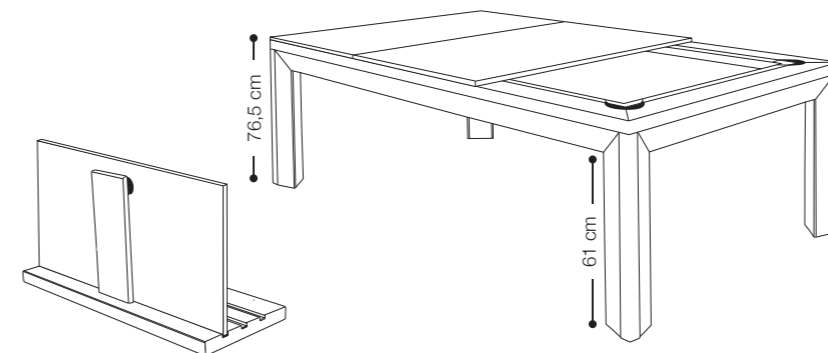

Version 8 pool avec descente intérieure
8 pool version with return ball system



Design - Bernard Moïse Studio

Diplômé de l'Ecole Nationale de Création Industrielle de Paris.
Graduated from the Advanced National School of Design and Industrial Creation, Paris.

| Type | Dimensions (cm) | | | | Hauteur / Height (cm) | | | Poids / Weight (Kg / Lb) |
|------------|-------------------|----------|----------------------|------------|-----------------------|-------|--------------------------|--------------------------|
| | Hors tout Overall | Jeu Game | Pièce* Pièce* Space* | Pieds Legs | Billard Pool | Table | Sous table Under table's | |
| 220 / 6,5' | 224 x 129 | 190 x 95 | 480 x 385 | 4 | 75 | 76,5 | 61 | 280 / 615 |
| 240 / 7' | 244 x 139 | 210x105 | 500 x 395 | 4 | 75 | 76,5 | 61 | 320 / 705 |

* Dimensions minimales de la pièce en utilisant une queue de 140 / Minimum space required to play with 4,5' cue

JEU / GAME

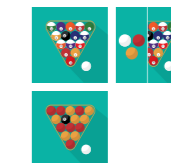

FINITIONS / FINISH



OPTION

Plus de détails / More details p43



Billards table

Table billiards

Les billards Chevillotte peuvent se transformer en table de salle à manger (ou bureau) grâce à l'option Plateau. Débordants ou ajustés, ces plateaux transforment en quelques seconde votre table de jeu afin d'accueillir selon la dimension de 6 à 10 convives.

Toutes les finitions sont disponibles afin d'assortir parfaitement plateau et table : plaquages bois, patines décoratives ou anciennes, laques, teintes satinées, gainage cuir...

Thanks to their table top, any Chevillotte pool table can be transformed into a dining table or a desk. In a few seconds your pool becomes a table gathering 6 to 10 guests depending on its dimensions.

All finishes are available to match perfectly table and tray: wood veneer, decorative or antique patinas, lacquers, satin painted, leather...



Kotibé / Solid African Mahogany



MDF / HDF



Kotibé / Solid African Mahogany

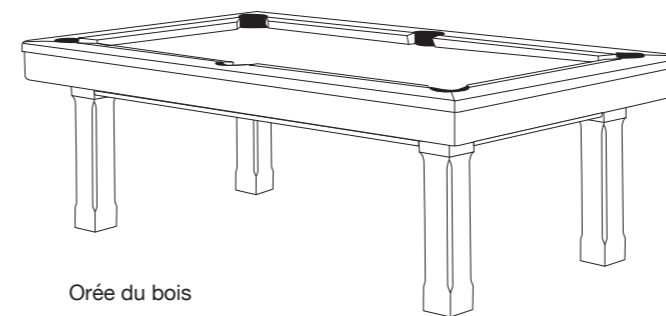

Orée du bois

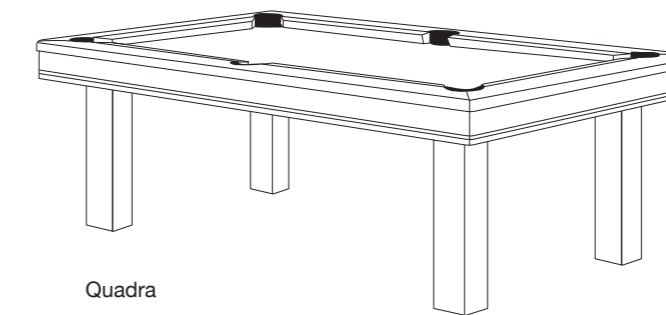

Quadra

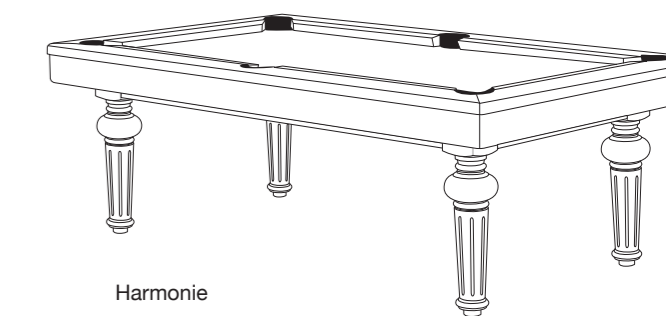

Harmonie

Dimensions (cm)

| Type | Hors tout Overall | Jeu Game | Pièce* Space* | Pieds Legs | Poids / Weight (Kg / Lb) |
|----------|-------------------|-----------|------------------|---------------|-----------------------------|
| 220 / 6' | 222 x 127 | 190 x 95 | 480 x 385 | 4 | 280 / 615 |
| 240 / 7' | 242 x 137 | 210 x 105 | 500 x 395 | 4 | 340 / 750 |

* Dimensions minimales de la pièce en utilisant une queue de 140 / Minimum space required to play with 4,5' cue

JEU / GAME

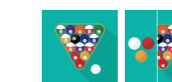

Plus de détails / More details p43

FINITIONS / FINISH





Bar



Baby-foot



Backgammon



Lustres
Lamps



Tables de jeu
Game table

Accessoires & Entertainment Room

Parce qu'un billard est un peu plus qu'un meuble, Chevillotte s'attache à proposer tous les accessoires et éléments de décoration permettant de créer une ambiance raffinée et conviviale. Du plus classique au style contemporain, Chevillotte offre des possibilités infinies adaptées à votre projet. Billards, tapis, sièges, éclairage, panneaux bois, bar, boîte à cigare, juke-box, flippers, fléchettes, baby-foot... Il n'y a pas de limite à votre imagination et à la nôtre.

A pool table is more than a furniture, Chevillotte offers endless possibilities of accessorising and decor to create the appropriate "atmosphere", an entirely personal feeling and style according to your project.

Billiards, carpets, seats, lights, bar, cigar box, juke-box, darts, football games... there is no limit to your imagination neither to ours.

Chevillotte vous accompagne dans la réalisation de vos projets :

Entertainment Room

est un service de conseil et d'aménagement de vos espaces de détente sur-mesure.

Taking into account your plans and wishes, we realise your made to measure project. We will supply you with 3D images of the entertainment area you have imagined.

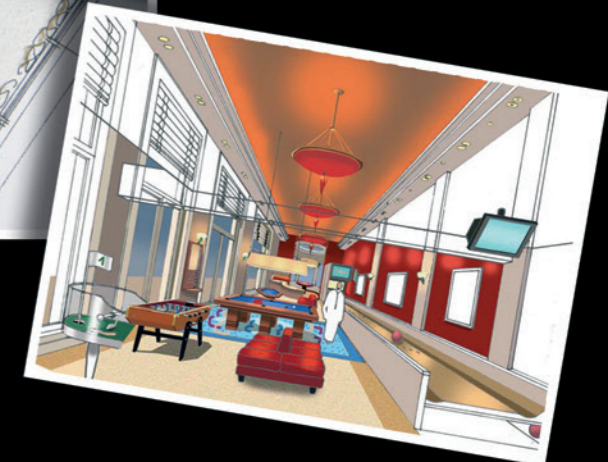
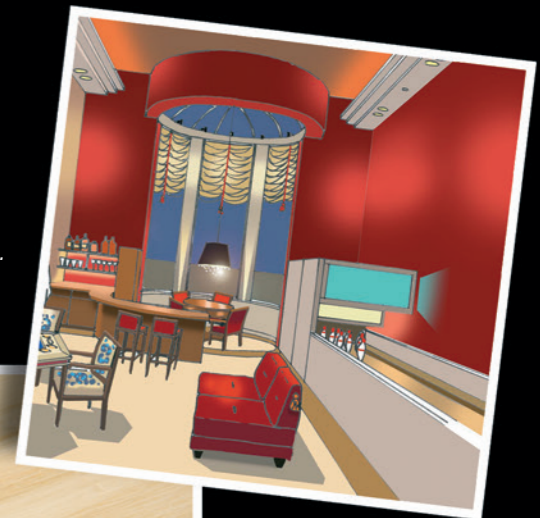

Catalogue complet des accessoires en téléchargement sur :
All accessories and decorative elements are consultable on:

www.chevillotte.com

Billards à la carte

Bespoke billiards

Depuis 1860, Chevillotte conçoit et fabrique des billards en combinant avec passion les qualités de jeu requises lors des plus prestigieuses compétitions internationales d'un côté et les goûts et les styles qui traversent les époques et les frontières d'un autre côté.

C'est ce savoir-faire qui est mis à la disposition des talents des créateurs du monde entier pour réaliser des billards sur-mesure pour le plus grand bonheur des joueurs désireux de posséder une pièce unique.

Since 1860, Chevillotte manufacture luxury pool tables which are selected in the best worldwide Tournaments, in all style and all kind of design.

Our know-how is yours to let you create the bespoke pool table your customers are dreaming of. From your sketch to a unique pool table: 100% hand-crafted in France. Your creativity is the limit.





Nuancier / Sample Chart

K Kotibé massif teinté / Solid tinted African mahogany



II Hêtre / Beech wood



Noyer massif du périgord / Solid aged French walnut



C Chêne massif (certifié PEFC*) / Solid oak (PEFC certified*)

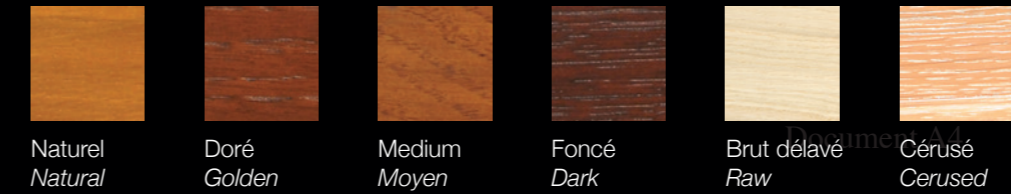

Plaquage Bois / Wood veneered



Cuir / Leather



L MDF & Laques / HDF & Lacquer

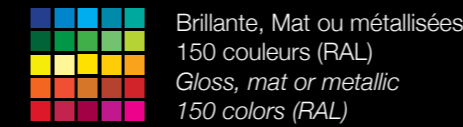

P Patine / Patina



Stratifié / Laminated



Aluminium



Jeu / Game



Carambole
Carom



Américain
American
(pockets or
ball return
system)



Mixte
Carom /
Américain
Mixed Carom/
American



Pyramide
Russian
Pyramid



Snooker



8 Pool



Système «Easy Clip»
breveté de mixité français
américain adaptable
sur tous nos modèles

Clipable set of angles to
transform easily an US Pool
into a Carom (for all model)

Angle

BILLARDS
Chevillotte
— Depuis 1860 —



*Entreprise
du Patrimoine
Vivant*

Manufacture

P.A. les Aulnaies
777 Rue de la bergeresse
45160 OLIVET - France
contact@chevillotte.com

Siège & Show-room

85 avenue du Président Wilson
93200 Saint-Denis - France
Tél. : 01 47 42 12 10
export@chevillotte.com